

Automatic satellite system Orbiter with SSC unit

User's guide



Register pattern - Design and specifications are subject to change without notice

Warnings.

- ALDEN declines all responsibility in the event of incident or accident if they are due to a non observation of the installation instructions or the way the product is used.
- **It is strictly forbidden to open any device.**
- **The warranty will no longer be applicable if you undertake such an action.**
- The reproduction of all or any part of this guide is forbidden without a written agreement from Alden.
- Alden draws your attention to the risks that may occur if the mounting is not correct. Alden declines all responsibility if the product is not mounted in the correct way and especially if it is installed by a non-professional person.

- **If any changes occur concerning the emission frequencies or the power of emission from the satellites, neither the salesperson nor the manufacturer are responsible .**
- **Neither the salesperson nor the manufacturer are responsible if a satellite or a programme come to disappear, if a free to air channel becomes scrambled or for any other modification that may affect the emission.**
- **Unpredictable events can not lead to any exchange, refund or compensation from the salesperson or the manufacturer.**
- **The reception areas of the satellites are given as a guidance.**

Security instructions:

- For security reasons, please close the antenna in high wind conditions. See the wind classification on page 7 to guide you. This satellite system will resist to winds up to 50 km/h. At this strength you **must** fold the dish down. Never raise the antenna with snow and/or ice on the dish. Always check if the way is free before raising the antenna. Clear off if necessary.
- It is an obligation to close the dish before starting the vehicle. Follow the closing procedure. Do not use the ignition security function to close the antenna.
- Make a complete check up before starting the vehicle.
- We advise to withdraw the fuse supplying the receiver in case of long periods without driving or to disconnect the supplying plug.
- **Remove the fuse from the electric circuit board of the satellite system and receiver before interfering on the general circuit board, or changing or connecting the battery. If the vehicle is equipped with a solar panel, also remove the fuse.**
- Always close the dish before leaving the vehicle.

Reminder :

- The system must be in a vertical position in a well ventilated space.
- Do not use existing coaxial circuits. The quality of the picture can be affected.
- Each link will weaken the signal.
- Cables of a different type can also change the quality of the picture.
- In any case, even when initial cables have been put in:
 - A direct line (no links) with a 5 A fuse must go from the unit to the battery for the + wire.
 - A direct line (no links) must go from the unit to the battery for the - wire.
- You must always use the cables that are provided.
- The warranty will no longer be applicable if these instructions are not followed.

Warning before using

When you travel a long distance, the satellite system will need more time to find and memorise the location of the satellites which will give you access to the best channels.

Example:

You are in Paris and you have used the satellite system. The next day, you drive to Strasbourg. You are still in the same geographical area, so your satellite system will need 40 to 70 seconds to find the satellite you have chosen.

However, if you travel thousands of kilometers towards the North or the South (from Paris to Milano), your satellite system will need 2 to 3 minutes to search and memorise the location of each satellite.

When you travel a great distance, for example from Berlin (Germany) to Malaga (Spain), it can take more than 10 minutes for the satellite system to locate and memorise each satellite.

Introduction

The SSC unit is a satellite search control system dedicated to find Panam Sat 7 / 10, Astra2, Hot Bird, AB3 and Hispasat. It can be used with any existing receiver (analog or digital) that allows the reception of the channels from the chosen satellite.

The SSC unit is especially designed for a use in a motorhome.

SSC unit description

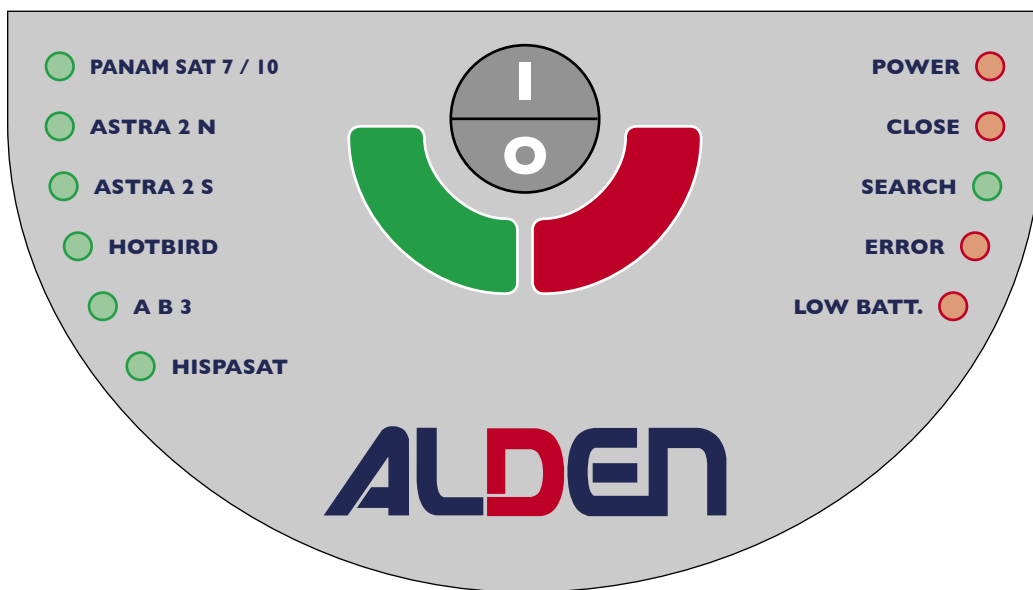

<i>Designation</i>	<i>Function</i>
On/Off	Switch on / off.
Green button	Choose a satellite.
Red button	Fold the antenna down.
Panam Sat 7 and 10	Satellites Panam 7 and 10 have been chosen.
Astra 2 N	The satellite Astra 2 N has been chosen.
Astra 2 S	The satellite Astra 2 S has been chosen.
HotBird	The satellite HotBird has been chosen.
AB3	The satellite AB3 has been chosen.
Hispasat	The satellite Hispasat has been chosen.
Power	The unit is on.
Close	The satellite system is folding down.
Search	The satellite system is in search mode.
Error	There has been an error during the search.
Low batt.	The battery is too low.

How to use the system

A. How to start.

Warning before using the system:

- Never switch to **O** position whilst using the SSC. The picture will disappear.
 - Never use the main switch on the SSC unit to close the antenna.
Always follow the instruction and undertake a complete closing procedure.
 - Never let the battery go under 10Volts. If the "Low bat" led comes on, this means the battery is under 9 Volts. In this case, you will have to go through the closing procedure to be able to use the SSC unit again.
 - If something happens to stop the dish from turning, the Error led will come on. For general safety reasons, always make sure the way is clear before putting the satellite system in search mode.
1. Switch the SSC on by switching to **I**. If the dish was up before doing this, it will automatically come down. No other manipulation will be able to be made until the dish is totally folded down.
 2. Use the **Green** button to select a satellite. Keep your finger down on this button to go from one satellite to another. Each time you change satellites, you will hear a tone. The satellites will change in the following order:

PANAM SAT Ę ASTRA 2 N Ę ASTRA 2 S Ę HOTBIRD Ę AB3 Ę HISPASAT Ę PANAM SAT...
 3. Once you have chosen a satellite, the led will flash for a few seconds and then stay on. The **Search** led will come on: this means that the system is searching the chosen satellite. Once the system has found the satellite the **Search** led will go off and you will hear 2 tones.

Please take note :

- when you use the system for the first time or if you have change area, the search may take a little longer.
 - if the Error led starts to flash, make sure you have not left the ignition key on, on your vehicle.
 - Everytime you turn the SSC unit on, it will automatically choose the last satellite. This avoids any manipulation if the choice of the satellite does not change.
4. Turn the TV on.
 5. Turn the receiver on and choose a programme.

B. Changing satellites whilst using the system.

1. By pressing the **Green** button, choose a satellite. Keep your finger down to go from one satellite to another. Everytime you go from one satellite to another, you will hear a tone. The satellites have been programmed in the following order :

PANAM SAT Ę ASTRA 2 N Ę ASTRA 2 S Ę HOTBIRD Ę AB3 Ę HISPASAT Ę PANAM SAT...
2. What to do if the satellite chosen on the SSC unit is different to the one on the receiver : select the right satellite using your receiver, then select this satellite with the **Green** button on the SSC unit.

C. How to close the dish.

1. Press on the red button of the SSC unit. The **Close** led will come on. It will only go off once the dish is completely folded down.
2. Now the dish is down, and that the **Close** led has gone off, switch the **O/I** switch of the SSC unit to the **O** position.

Warning: Never forget to switch the SSC unit off once the antenna is completely folded down.

3. Turn the receiver and the TV off.

How to use the optional remote control

If you choose the SSC with a remote control and an infrared remote sensor, it is then possible to set the search and close the satellite system at a distance.

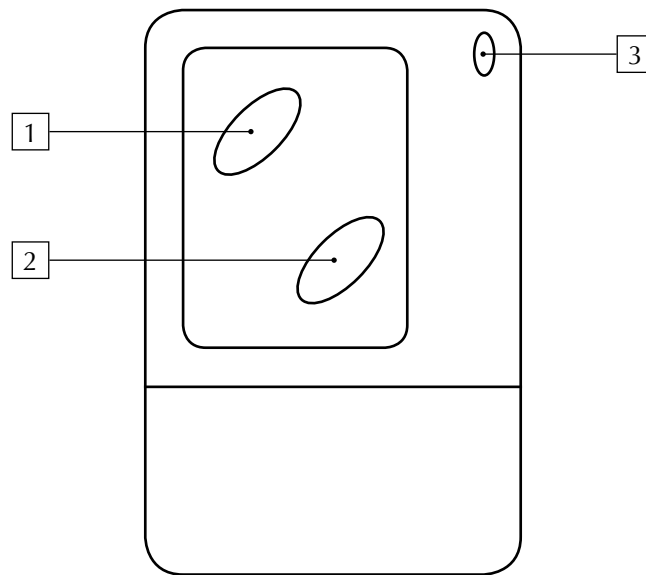

<i>Part n°</i>	<i>Function</i>
1	Choose a satellite
2	Fold the antenna.
3	Warning Light.

1. Point the remote control towards the Infrared remote sensor.
2. To choose a satellite, press 1 until the signal light matching the satellite comes on.
3. To fold the satellite system down, press 2 until the “close” signal light comes on at the front of the unit.

Information :

Everytime you use the remote control, the warning light will come on. (3).

Important :

Everytime you use the remote control, you will also hear a tone which confirms your choice.

How to change the battery:

To change the battery in the remote control, use a screw driver to remove the cover at the bottom right hand side of the back of the remote control. Change the battery and make sure it is in the right way. Close the remote control and screw the cover back on..

Information :

The remote control will only work with CR2450 type batteries.

What to do if the system breaks down

- Bad picture:

Improve the position of the satellite system by pressing **1** on the remote control or the **green button** on the front of the SSC unit.

- How to change the satellite:

See page 5.

- In case of a power cut:

Check the connections, the cables and the fuse.
Follow the closing procedure and then use as normal

- The satellite system does not find the satellite:

Make sure there is nothing stopping the antenna from turning. (tree, house...).
The frequency of the satellite may change, in this case, the satellite system will not be in the right position.
Get in touch with a technician or go on our web site: www.alden.fr

- The remote control no longer works:

Check and change the batteries
Make sure the infrared remote sensor is not damaged and that it is connected to the unit (SSC).

- The satellite system will not fold down:

Start the vehicle and see if the antenna will come down. If the antenna does not fold down, stop the vehicle and take the dish down by removing the 2 plastic screws and the 2 M8 screws on the red part.

Wind classification

When the wind gets to 5, we advice to fold your mobile equipment down (solar panel, satellite systems).
When it gets to 7, you **MUST** fold everything down.

Strenght	Name	Speed				Effect
		Knot		Km/h		
0	Calme	1	1	1	1	Smoke is rising straight up.
1	Very slight breeze	1	3	1	5	Smoke gives the direction of the wind; windvanes are not moving.
2	Slight breeze	4	6	6	11	You can feel the wind on your face; leaves will move.
3	Small breeze	7	10	12	19	Flags are up and leaves rustle.
4	Pleasant breeze	11	16	20	28	Dust and sand are lifting from the ground; small branches are bending.
5	Strong breeze	17	21	29	38	Small trees are swaying and the tops of all trees are moving.
6	Cold wind	22	27	39	49	You can hear the wind whistle.
7	Strong cold wind	28	33	50	61	All the trees are moving; you can only just walk facing the wind.
8	Gust of wind	34	40	62	74	You cannot walk facing the wind; some branches are breaking off.
9	Strong gust of wind	41	47	75	88	You cannot walk facing the wind; the wind is damaging buildings.
10	Storm	48	55	89	102	There is a lot of damage; young children of 12 cannot keep their feet on the ground (they can fly away!)
11	Violent storm	56	63	103	117	
12	Hurricane	64	plus	118	plus	

**We remind you that if you forget to fold the system down when the wind gets strong,
the warranty will be cancelled.**

Cable connection

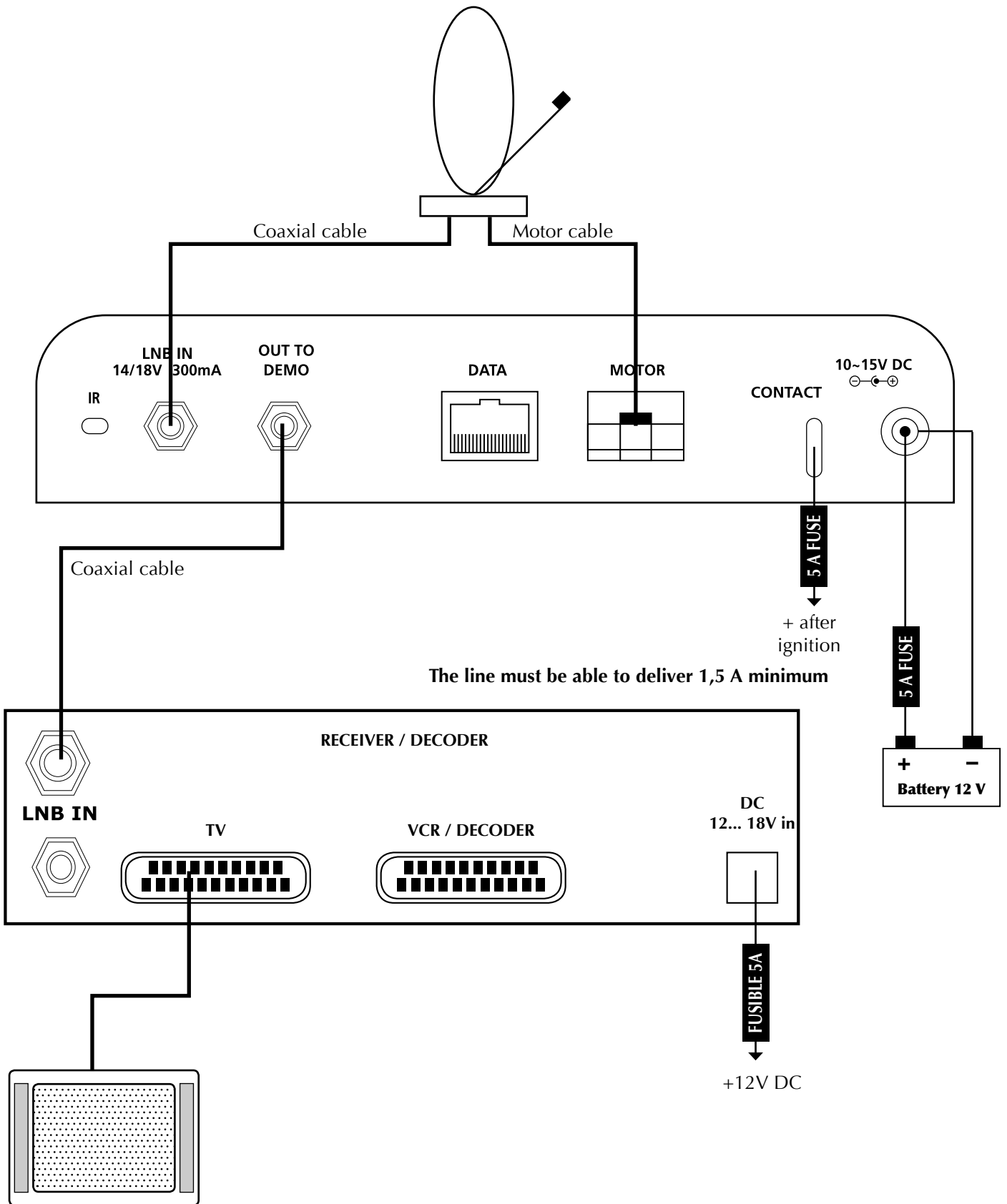

SSC connection layout

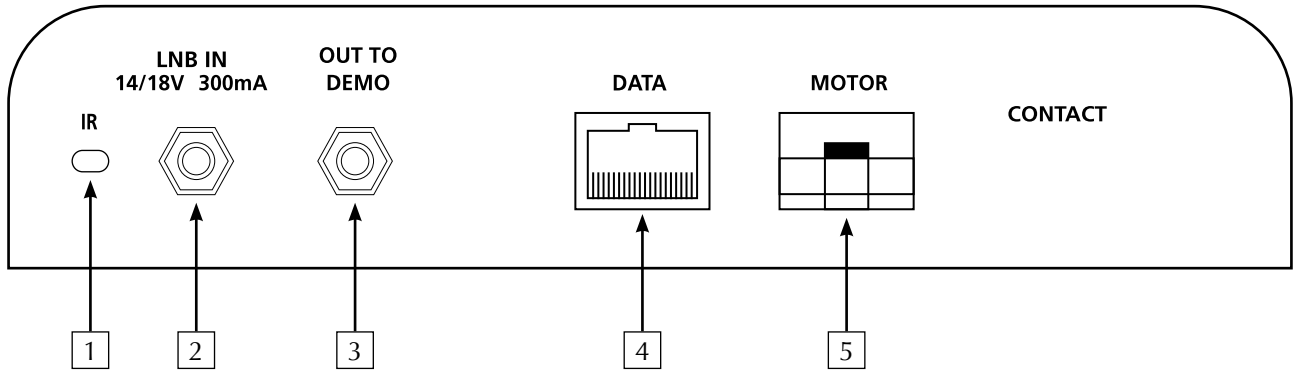

<i>N° : description</i>	<i>Type of connection</i>	<i>Description of inputs / outputs</i>
1 : IR	RJ-11	Infrared control. A remote sensor is delivered with the remote control (in option).
2 : LNB in	Coaxiale type F	Connection with the LNB from the antenna.
3 : Out to demo	Coaxiale type F	Connection used between the unit and the receiver.
4 : Data	RJ-45	Used to transfer the updating data.
5 : Motor	Power	Used for the motorization of the satellite system.
6 : Contact	Cosse	Safety device : will fold the antenna and is connected to the vehicle ignition.
7 : 10-15V DC	Jack	Main supply.

Reminder :

- The system must be in a vertical position in a well ventilated space.
- Do not use existing coaxial circuits. The quality of the picture can be affected.
- Each link will weaken the signal.
- Cables of a different type can also change the quality of the picture.
- In any case, even when initial cables have been put in:
 - A direct line (no links) with a 5A fuse must go from the unit to the battery for the + wire.
 - A direct line (no links) must go from the unit to the battery for the - wire.
 - A direct line (no links) with a 5A fuse must go from the unit to the "+ after ignition" located on the ignition key or on the main unit.
- Never use the "+ after ignition" on the fridge, the steps or the battery separator.
- You must always use the cables that are provided.
- The warranty will no longer be applicable if these instructions are not followed.

Technical characteristics of the SSC unit

Bande de fréquence : KU

Fréquence : 10,7 à 12,75 GHz

Polarisation : Horizontale et Verticale

Alimentation : 12 V DC

Puissance : 10 W maximum

Température ambiante d'utilisation : -20°C à +50°C

Taux d'humidité ambiant : 85 % maximum

Dimensions : l = 175 mm
h = 130 mm
p = 45 mm

Poids : 0,29 kg



Directive DEEE (Union européenne et EEE uniquement).

Ce symbole indique que, conformément à la directive DEEE (2002/96/CE) et à la réglementation de votre pays, ce produit ne doit pas être jeté avec les ordures ménagères. Vous devez le déposer dans un lieu de ramassage prévu à cet effet, par exemple, un site de collecte officiel des équipements électriques et électroniques (EEE) en vue de leur recyclage ou un point d'échange de produits autorisé qui est accessible lorsque vous faites l'acquisition d'un nouveau produit du même type que l'ancien. Toute déviation par rapport à ces recommandations d'élimination de ce type de déchet peut avoir des effets négatifs sur l'environnement et la santé publique car ces produits EEE contiennent généralement des substances qui peuvent être dangereuses. Parallèlement, votre entière coopération à la bonne mise au rebut de ce produit favorisera une meilleure utilisation des ressources naturelles. Pour obtenir plus d'informations sur les points de collecte des équipements à recycler, contactez votre mairie, le service de collecte des déchets, le plan DEEE approuvé ou le service d'enlèvement des ordures ménagères.

(EEE : Norvège, Islande et Liechtenstein)